



# TIGER CRANES

## Model 3215E Specifications

### Model 3215E Specifications

#### Dimensional Specifications:

- 15' Reach
- 9-15' Hydraulic Boom Extension
- 12'8" Lifting Height (from base of crane)
- 34" Storage Height (from base of crane)
- 119" Overall Storage Length
- 14"X14" Mounting Space Required
- 12" Square Bolt Mounting Pattern
- 1/4" X 80' Aircraft Winch Cable
- 745 lbs. Operating Weight

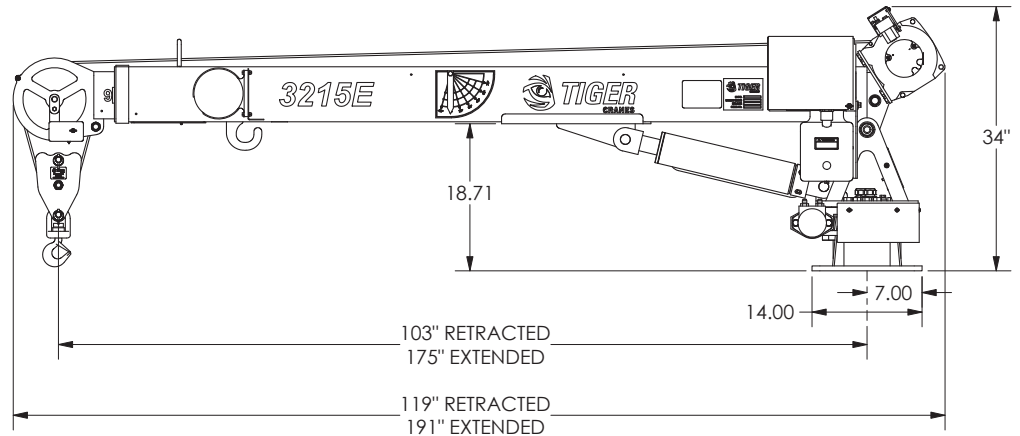

#### Performance Specifications:

- 11,000 ft-lb Crane Rating
- 13,300 ft-lb Maximum Crane Lifting Moment
- 3200 lb Double Line Lift Capacity
- 400 Degrees of Rotation
- -8 Degrees to +81 Degrees Boom Angle
- Winch Performance

LOAD	LIFTING SPEED
0 lbs	22 FPM
500 lbs	18FPM
750 lbs	18FPM

#### Standard Features:

- 20' tethered control included for operation
- Anti two block & overload protection with lighted indication
- 10 VDC Cartridge Valves with manual overrides
- Electric planetary winch. Boom mounted for easier stowing.
- Sealed turret
- Crane lift and extension cylinders are equipped with counterbalance safety valves.
- Powder coated base, turret shield and inner boom, with PPG Delfleet polyurethane paint on other components.
- This crane is designed to meet the requirements of ANSI/ASME B30.5 (2011) and OSHA 1910.180.

#### Minimum Chassis/Power Requirements:

- 11,000 lbs. GVW Rating
- 60" Cab to Axle
- 11,000 ft-lb Rated crane tower reinforcement and outrigger
- 90 Amp Alternator
- 700 Cold Cranking Amp Battery





# TIGER

## CRANES

### Model 3215E Specifications

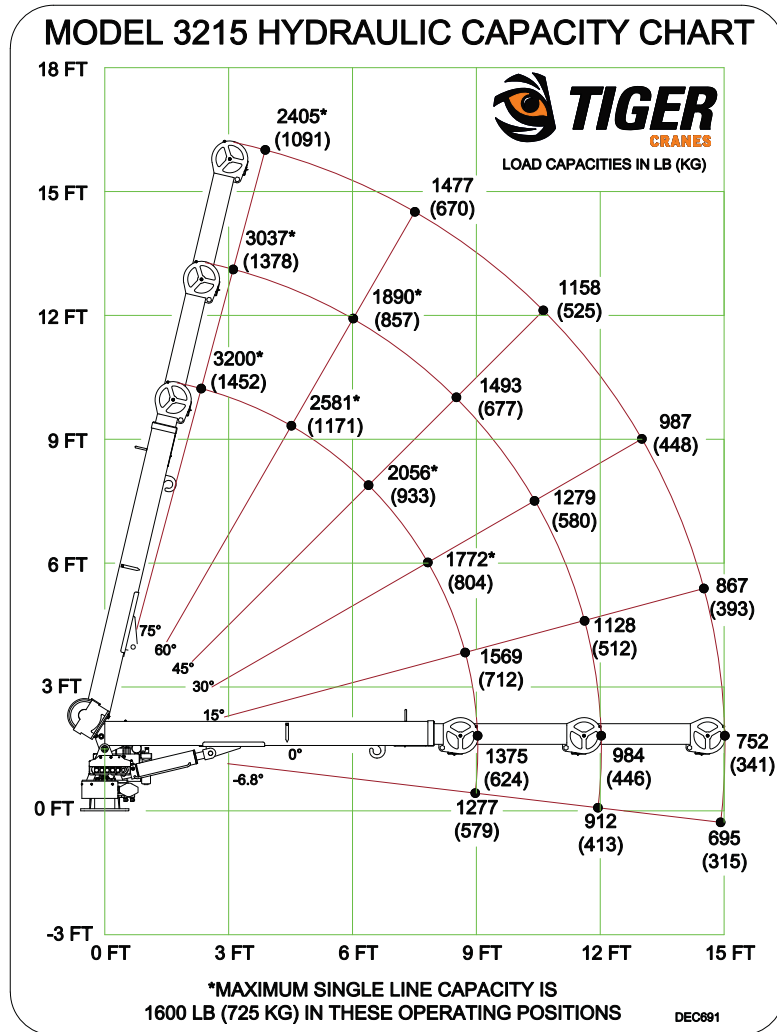

### Bolt Hole Pattern

