



# TIGER CRANES

## Model 2060 Specifications



### Model 2060 Specifications

#### Dimensional Specifications:

- 5' Reach
- 3'-4'-5' Manual Boom Extension
- 6 Lifting Height (from base of crane)
- 57" Storage Height
- 47" Overall Storage Length
- 12"x12" Mounting Space Required (for base of crane)
- 4 Bolt 9"x10" Mounting Pattern
- 3/16" X 40' Winch Cable
- 280 lbs. Operating Weight

#### Performance Specifications:

- 6,000 ft-lb Crane Rating
- 2,000 lb Double Line Lift Capacity
- 360 degrees of continuous rotation with manual band brake
- 0-21-45 Degrees Boom Angle
- Winch Performance - First Layer

LOAD	PART LINE	LIFTING SPEED
0 lbs	1	23.5 FPM
300 lbs	1	21 FPM
600 lbs	1	19 FPM
900 lbs	1	17 FPM
1200 lbs	2	7.5 FPM

#### Standard Features:

- 12' tethered control included for operation
- Electric planetary winch.
- Powder coated components.

#### Minimum Chassis/Power Requirements

- 8,500 lbs. GVW Rating
- 60 Amp Alternator
- 85 amp/hr Battery
- 500 Cold Cranking Amp Battery

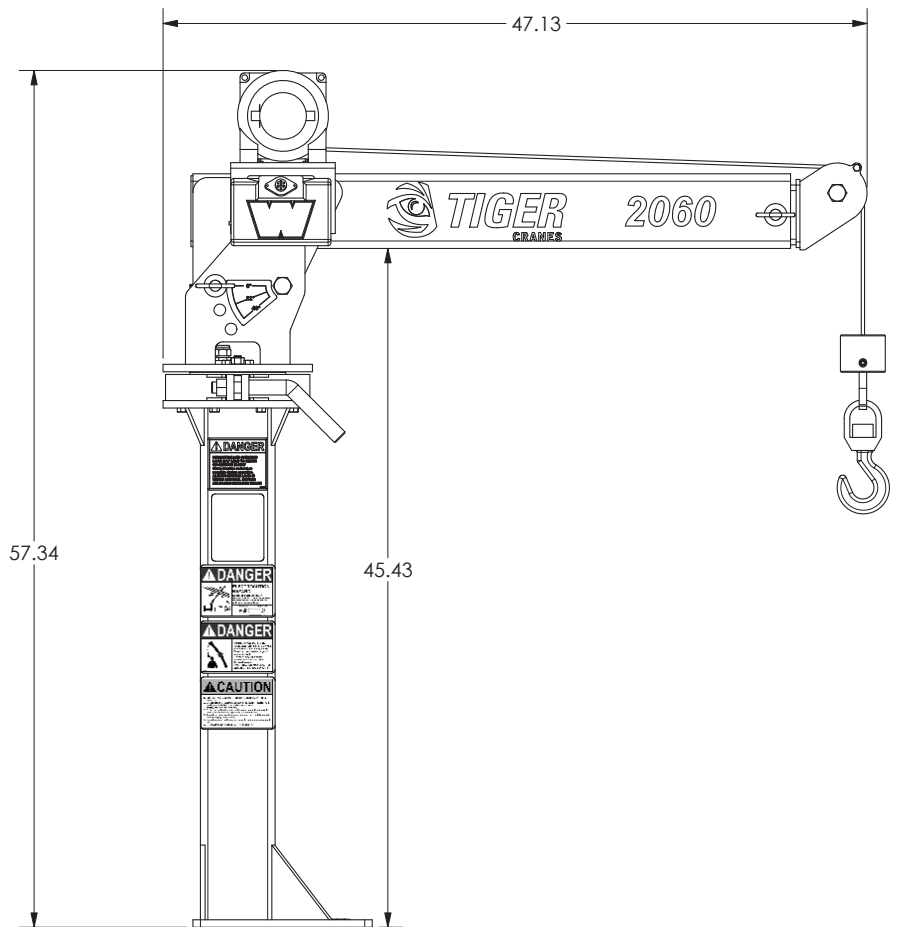



# TIGER

## CRANES

### Model 2060 Specifications

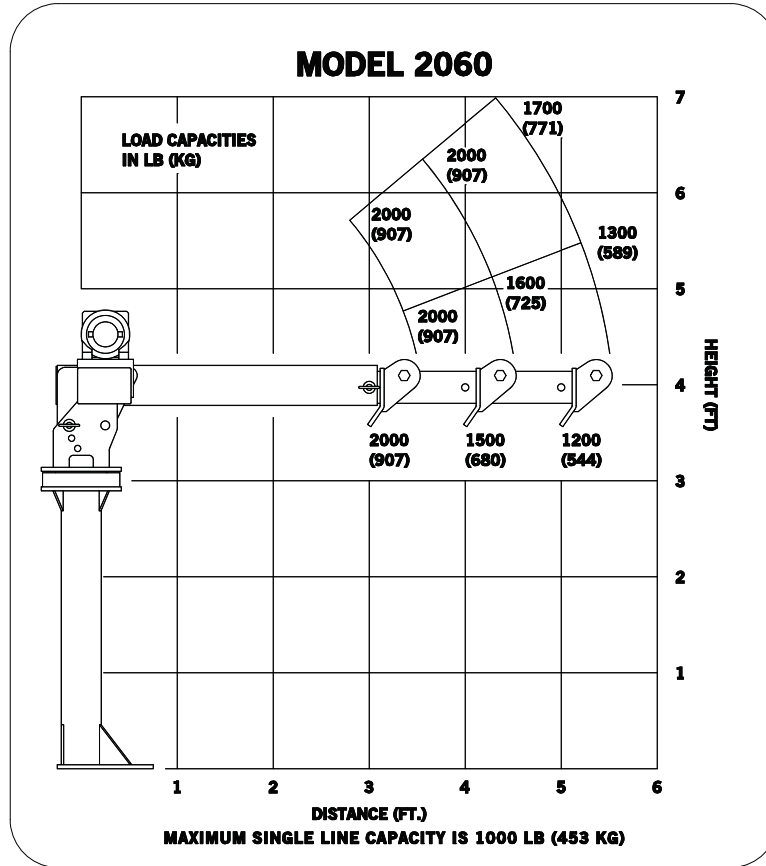

#### Bolt Hole Pattern

