

# Sullivan Palatek®

**D1300-D1800  
Portable Series  
TIER 3**



**SmartEquip™**

## FEATURES

- Large 321mm Diameter Twin Screw
- Air End Manufactured by Sullivan-Palatek, Comes With Exclusive Three Year Warranty
- Automatic 0 to 100% Capacity Control
- 8" Closed Start, Inlet Valve
- 3" Service Connection
- Oil Level Sight Gauge
- Caterpillar or Cummins Engine
- Steel Fuel Tank
- Four Point Lifting Bail
- Dual Axle Running Gear
- Electric Brakes
- Adjustable 3" Lunette Eye
- Noise Level Limited to Maximum of 76 dBA at 7 Meters
- Automatic Shutdown and Protection System
- Direct Drive
- Containment Base
- Large Service Doors for Easy Maintenance
- Automatic Blowdown Valve
- Dual Air Outlets (with Aftercooler option)
- **NEW!** Sullivan-Palatek Electronic Controller (SPEC)
  - *Digital Readouts:*
    - Compressor temperature
    - Engine oil pressure
    - Engine temperature
    - Voltmeter
    - Tachometer
    - Fuel level - low fuel warning and shutdown
    - Complete engine diagnostic tool
    - Measurement converter
    - Multilingual capabilities
    - Waterproof up to six feet
- Options
  - Built in Aftercooler and Filters
  - Hydraulic Brakes

**PLUS MANY MORE**



# TECHNICAL DATA

## DIMENSIONS

(Metric in Parentheses)

Dimensions & Specifications subject to change without notice

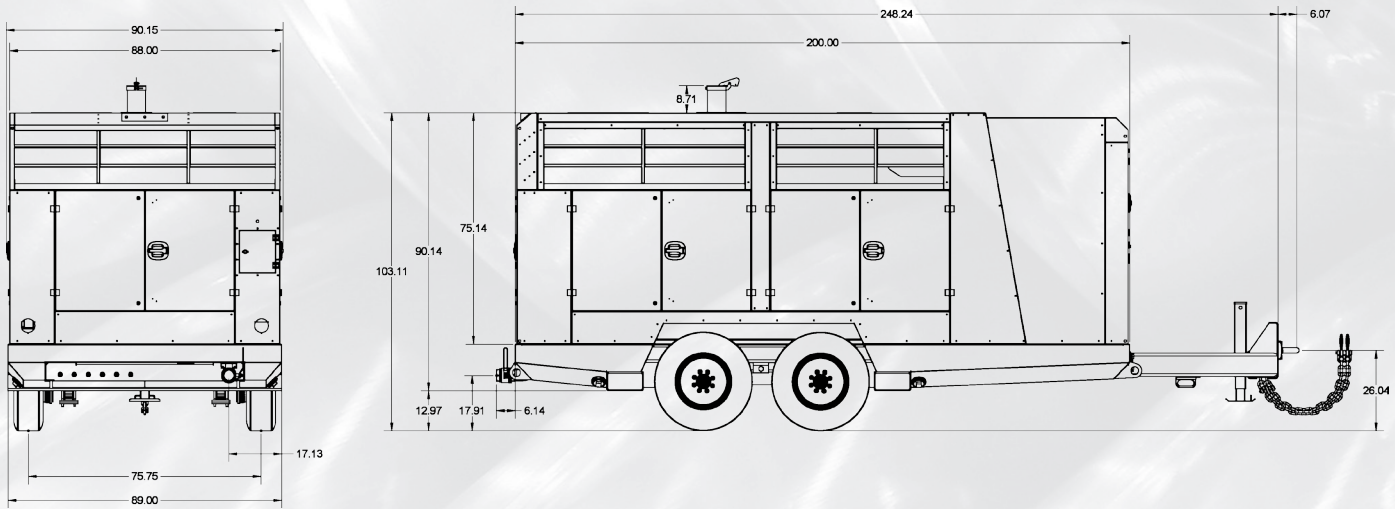

## SPECIFICATIONS

COMPRESSOR SPECS		D1300PHCU	
Type	Single Stage, oil flooded rotary screw	Rated Delivery	1300 cfm (37 m <sup>3</sup> /min)
Ambient Oper. Temp. Range	-40° to +125°F (-40° to +52°C)	Rated Operating Pressure	150 psig (10.3 Bar)
Oil Capacity	55 gal. (208 L)	Engine HP	485 HP
Total Receiver Volume	21 ft. <sup>3</sup> (595 L)	Full Load Speed	1800 RPM
Air Service Connections	3" NPT	D1600PCU	
Type Cooling System	Oil to Air	Rated Delivery	1600 cfm (45 m <sup>3</sup> /min)
Type Air Intake System	Two Stage Dry	Rated Operating Pressure	125 psig (8.6 Bar)
Type of Control	0-100% Demand	Engine HP	485 HP
Tire Size	235/75 R17.5	Full Load Speed	1900 RPM
Operating Pressure Range	70-150 psig (4.9 - 10.3 Bar)	D1600PHCU	
Estimated Weight, Serviced	20,000 lbs	Rated Delivery	1600 cfm (45 m <sup>3</sup> /min)
		Rated Operating Pressure	150 psig (10.3 Bar)
		Engine HP	535 HP
		Full Load Speed	2000 RPM
ENGINE SPECS		D1800PCU	
Type	Diesel Tier 3	Rated Delivery	1800 cfm (51 m <sup>3</sup> /min)
Model Number	QSX15	Rated Operating Pressure	100 psig (6.9 Bar)
Number of Cylinders	6	Engine HP	485 HP
Bore and Stroke	5.4" x 6.7" (137 x 169mm)	Full Load Speed	2100 RPM
Displacement	915 in <sup>3</sup> (15 L)	D1800PMCU	
Total Oil Capacity	12 gal. (45.41 L)	Rated Delivery	1800 cfm (51 m <sup>3</sup> /min)
Cooling System Capacity	18.5 gal. (70 L)	Rated Operating Pressure	125 psig (8.6 Bar)
Battery Rating	24 Volts	Engine HP	535 HP
COA @ 0°F	1400 Amps per Battery	Full Load Speed	2100 RPM
Idle Speed	1400 RPM		
Fuel Tank Capacity	224 gal (1,018 L)		

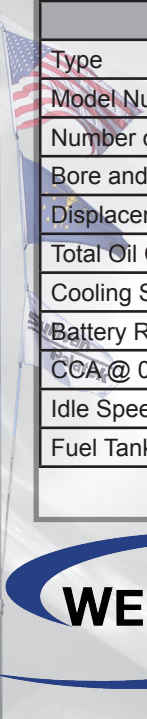

191 Kelly Road  
Quakertown, PA 18951

www.Wenzco.com

Tel: 800-346-7805  
Fax: 610-966-2287

Email: sales@Wenzco.com



D1300-1800SPEC-FP 4/15 1M